

# Quincalux

HANDLING LUXURY SINCE 1942

Architectural Hardware

Contemporary Collection 2022 - 2023

Q 1942



Gheithof Léon, Demeestre Jan en Bosken Georges

## HANDLING LUXURY SINCE 1942

At Quincalux we have been inspiring Architecture with Craftsmanship since 1942. For eighty years we have been blending tradition and innovation, made by hand in Belgium, with a never-ending search for improving techniques. Driven by quality, we solely craft our door handles into timeless designs with noble materials such as brass and aluminium as these age perfectly and are sustainable, a characteristics which we keep close to heart. Today, our product range extends in two directions : a traditional Classic Collection and an innovative Contemporary Collection.

Chez Quincalux, nous inspirons l'architecture par notre savoir-faire artisanal depuis 1942. Depuis quatre-vingts ans, nous allions tradition et innovation, fabrication à la main en Belgique et recherche permanente d'optimisation de nos techniques. Passionnés par la qualité, nous réalisons uniquement des poignées de porte au design intemporel avec des matériaux nobles tels que le laiton et l'aluminium, qui vieillissent parfaitement et sont durables, un aspect qui nous tient particulièrement à cœur. Aujourd'hui, notre gamme de produits est axée vers deux directions : une collection classique traditionnelle et une collection contemporaine placée sous le signe de l'innovation.



*Photography: Kristof Delbart*

## Four generations of Belgian craftsmanship

Design and craftsmanship, hand-made in Belgium. Quincalux guarantees traditional craftsmanship with modern technological ingenuity. Every part turned, milled hot-pressed or cast in a sand bed is considered and detailed with care and passion for the craft. From the crank pin to the adjusting bolt; from the groove to the handle, it is always the result of a meticulous design and production process. Cutting-edge innovative technology helps polish the true métier, but the hand always comes first at Quincalux. The knowledge is at hand and passed on from generation to generation. Every new product created by designers for architects always passes through many hands.

That's what it's always meant for.

## Quatre générations d'artisanat belge

Design et artisanat, fabrication à la main en Belgique. Quincalux garantit un artisanat traditionnel combiné à l'ingéniosité technologique moderne. Chaque pièce tournée, fraisée, pressée à chaud ou coulée dans un lit de sable est manipulée et détaillée avec soin et passion pour le métier. Du maneton à la vis de réglage, de la rainure à la poignée, le processus de conception et de production est toujours appliqué dans le souci du détail. Une technologie innovante de pointe soutient le vrai métier, mais Quincalux privilégie toujours le travail à la main. Notre savoir spécifique se transmet de génération en génération. Chaque nouveau produit créé par des designers pour des architectes passe toujours par plusieurs mains avant validation.

L'objectif pour lequel il est initialement conçu.

Imperial  
20



Monaco  
46



Montreux  
66



Helsinki  
26



Como  
48



Royal  
72



Athena  
32



Palma  
54



Quito  
78



Copenhagen  
38



Oslo  
60



Caracas  
80



Cassis  
44



Lausanne  
64



Q-Wing  
82



Stockholm  
84



Madrid  
100



Q-Line 703  
112



Luxembourg  
88



Brussels  
102



Q-Line 704  
113



Berlin  
92



Art 127  
109



Accessoires  
114



Luxor  
96



Q-Line 700  
110



Patines / Finishes  
119

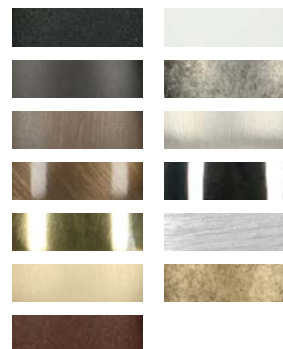

Lisbon  
98



Q-Line  
111



## Design Driven

Quincalux is proud to work with internationally renowned designers, architects and interior architects for the creation of their new collections.

They are supported by the internal development team and the creative director, Frederik Delbart.

## Axé sur le design

Quincalux collabore avec des designers, des architectes et des architectes d'intérieur à la renommée internationale pour la création de ses nouvelles collections.

Ils sont soutenus par l'équipe de développement interne et par le directeur créatif, Frederik Delbart.







*Imperial*



## FREDERIK DELBART

Creative Director  
& Designer

Frederik Delbart's interdisciplinary approach includes product design as well as strategic design management and creative direction. After his studies at La Cambre Arts Visuels, his career took off. This is demonstrated by numerous product introductions, several awards as well as long-term strategic partnerships with companies such as Quincalux. Since 2015, he has been active as Creative Director for Quincalux, collaborating closely with the direction and setting the lines for future strategy, collections and branding and bringing the company's brand to the next level. In 2018, Delbart was awarded the prestigious title of 'Belgian Designer of the Year'. He's internationally acclaimed for his thoughtful design philosophy, in which nothing is left to chance. From concept to design and from use of materials over production process to implementation, marketing and branding, even the subsequent logistics chain does not escape his attention. The collections from his hand are Caracas, Quito, Oslo, Royal, Imperial, Copenhagen, Athena, Kyoto and Osaka.

*L'approche interdisciplinaire de Frederik Delbart comprend le design de produits ainsi que la gestion stratégique du design et une direction créative. Après ses études à La Cambre Arts Visuels, sa carrière a pris son envol. En témoignent de nombreuses introductions de produits, plusieurs prix ainsi que des partenariats stratégiques à long terme avec des entreprises telles que Quincalux. Depuis 2015, il endosse le rôle de directeur créatif pour Quincalux, en étroite collaboration avec la direction. Il établit la stratégie, les collections et le branding, et élève la marque de l'entreprise à un niveau supérieur. En 2018, Frederik Delbart s'est vu attribuer le prestigieux titre de Designer belge de l'année. Il est également reconnu au niveau international pour sa philosophie de conception réfléchie, dans laquelle rien n'est laissé au hasard. Du concept au design et de l'utilisation des matériaux au processus de production en passant par la mise en œuvre, le marketing et le branding, même la chaîne logistique ultérieure n'échappe pas à son attention. Il a notamment conçu les collections Caracas, Quito, Oslo, Royal, Imperial, Copenhagen, Athena, Kyoto et Osaka.*



*Helsinki*



## JEFFREY HUYGHE

Designer

Jeffrey Huyghe graduated as an industrial product designer at Howest, Kortrijk. With a heart for engineering, Jeffrey likes to experiment with geometrical shapes and dynamic interactions. This translates in an interesting tension where minimalism and materialisation meet state-of-the-art engineering.

Examples are multi-awarded architectural lighting designs like Semih (2016) and Marbul (2018) where complex hidden rotational systems are disguised as pure designs. Recently he started his own studio where, beyond lighting, he can push further the boundaries of the interaction between materials and mechanics. The new Helsinki Collection was designed by Jeffrey Huyghe.

*Jeffrey Huyghe est diplômé en tant que designer de produits industriels à Howest, Courtrai. Avec un cœur pour l'ingénierie, Jeffrey aime expérimenter les formes géométriques et les interactions dynamiques. Cela se traduit par une tension intéressante où minimalisme et matérialisation rencontrent une ingénierie de pointe.*

*Des exemples sont des conceptions d'éclairage architecturales multi-primées comme Semih (2016) et Marbul (2018) où des systèmes de rotation cachés complexes sont déguisés en conceptions pures. Il a récemment créé son propre studio où, au-delà de l'éclairage, il peut repousser les limites de l'interaction entre les matériaux et la mécanique. La toute nouvelle collection Helsinki a été conçue par Jeffrey Huyghe.*



*Como*



## LIEVEN MUSSCHOOT & CAS MOOR

Designers

Interior architect Lieven Musschoot has an impressive track record in the field of hospitality projects. In the many trendy bars and acclaimed restaurants, he always manages to add a new dimension to the concept of 'tasteful design'. No detail goes unnoticed.

Since 2014 he has also been reinforced by Cas Moor, a pur sang product designer. Together the duo develops complete projects, from interiors to custom lighting, furniture and accessories.

LMCM designed the Como collection for Quincalux, in which you can experience the grandeur of the famous Alpine lake.

*L'architecte d'intérieur Lieven Musschoot peut se targuer de posséder un palmarès impressionnant dans le domaine des projets d'accueil. Mieux que quiconque, il sait toujours ajouter une nouvelle dimension au concept de « design de bon goût » dans les nombreux bars branchés et restaurants de renom. Aucun détail ne passe inaperçu.*

*En 2014, il a été rejoint par Cas Moor, un designer de produits pure souche. Ensemble, le duo développe des projets complets, des intérieurs aux luminaires sur mesure, en passant par le mobilier et les accessoires.*

*LMCM a conçu la collection Como pour Quincalux, qui respire la grandeur du célèbre lac alpin.*



*Palma*





## JULIEN RENAULT

Designer

Julien Renault grew up outside Paris and attended design schools both in France (Reims School of Art and Design) and in Switzerland (ECAL). Two different cultures and approaches to design which have partly shaped Renault's own way of addressing his work. On the one hand artistic, free and personal, on the other hand systemic, objective and rational. Renault uses both pragmatism and intuition when he dives into a new project, creating a dialogue between sense and sensibility. The cross-disciplinary output is suitable for a designer such as Renault who is grounded in his vision of essentialism. Behind each apparently plain project lurks a bunch of well-considered references and the mindset of a designer who leaves nothing to chance. Renault thinks and works conceptually and throughout each project follows a precise and recognisable image. Whether the assignment is a product design, a photo shoot or an interior space, it starts with a defining element which accompanies the concept from start to finish.

For Quincalux he created the Palma Collection in which he sublimates the lines of a palm into an elegant door and window handle.

*Julien Renault a grandi en région parisienne et a fréquenté des écoles de design en France (École Supérieure d'Art et de Design de Reims) et en Suisse (ECAL), deux cultures et deux approches différentes du design qui ont contribué à façonner la manière dont Renault aborde son travail. D'un côté artistique, libre et personnel, de l'autre systémique, objectif et rationnel. Renault se sert de son pragmatisme et de son intuition lorsqu'il se plonge dans un nouveau projet, créant ainsi un dialogue entre le sens et la sensibilité. Cette approche interdisciplinaire convient à un designer tel que Renault, ancré dans sa vision de l'essentiel. Derrière chaque projet en apparence banal se cache un ensemble de références réfléchies et l'état d'esprit d'un designer qui ne laisse rien au hasard. Renault pense et travaille de manière conceptuelle et chaque projet suit une image précise et reconnaissable. Qu'il s'agisse d'un design de produit, d'une séance photo ou d'un espace intérieur, tout commence par un élément déterminant qui accompagne le concept de A à Z. Il a créé pour Quincalux la collection Palma, qui sublime les lignes d'un palmier en une élégante poignée de porte et de fenêtre.*



*Copenhagen*

# Contemporary Collection

2022 - 2023

The innovative and refined experience of modern architecture.

*L'expérience innovante et raffinée de l'architecture moderne.*





Imperial



Imperial



# Imperial

Design by Frederik Delbart

The Imperial Collection captures the light with its many facets while respecting ergonomics. Uniting the extended know-how of Quincalux with avant-gardist innovative design, the Imperial Collection is crafted in solid brass with extreme precision.

*La Collection Imperial capte la lumière avec ses multiples facettes tout en respectant l'ergonomie. Alliant le solide savoir-faire de Quincalux à un design novateur avant-gardiste, la Collection Imperial est réalisée en laiton massif avec une extrême précision.*

Material: Brass/Laiton DIN 17166

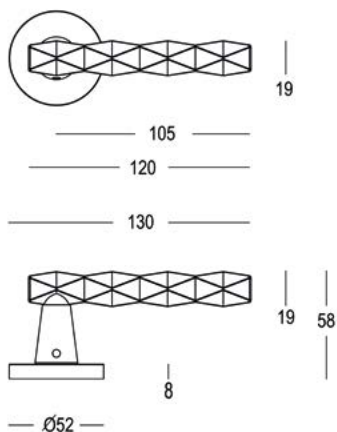

Art. 200-RO



Dark bronze  
Bronze foncé  
Donker brons  
(42)



Bright nickel  
Nickel brillant  
Nikkel blinkend  
(09)



Satin Brass  
Laiton Satiné  
Messing Satijn  
(22)

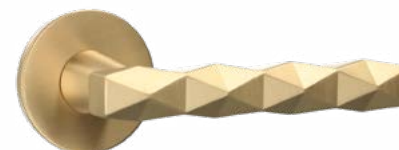

Matt Bronze  
Bronze Mat  
Mat Brons  
(41)



Inox Look  
Nickel mat satiné  
(99)



# Imperial



Art. 200-KT



-30-



14

-19-

Art. 200-21 (210mm)



300

-□19-



210

-41-

-60-

Ø23

Ø23





Art. 200-R0

Art. 200-DK (L)

Art. 200-DK (T)

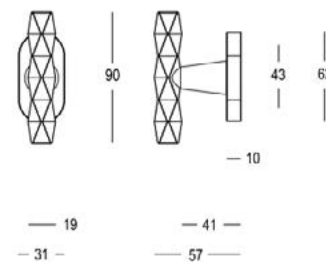
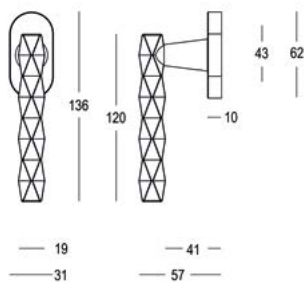
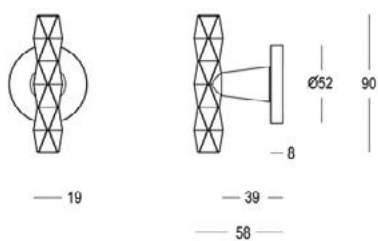





Helsinki

1



# Helsinki

Design by Jeffrey Huyghe

The Helsinki Collection is recognized by simple, flowing lines. The door handle and its base enter into a dialogue, they create one refined, minimalist whole.

*La collection Helsinki se distingue par ses lignes simples et fluides. La poignée de porte et sa base entrent en dialogue, créant un ensemble raffiné et minimaliste.*

Material: Aluminium EN AW 6060

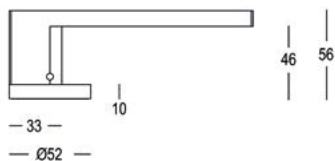
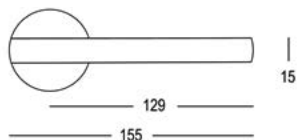

Black textured  
Noir mat structuré  
Mat zwart textuur  
(60)



White textured  
Blanc mat structuré  
Mat wit textuur  
(65)

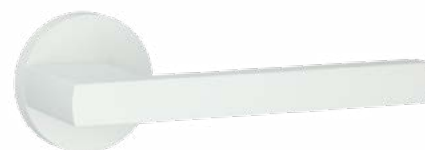

Art. 199-RO



# Helsinki



Art. 199-KT

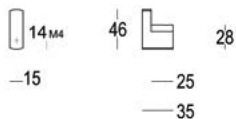

Art. 199-28 (128mm)  
Art. 199-60 (160mm)

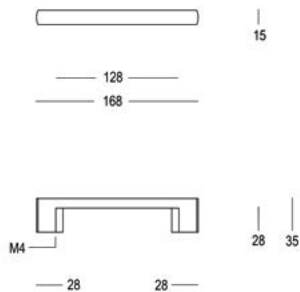

Art. 199-30 (300mm)

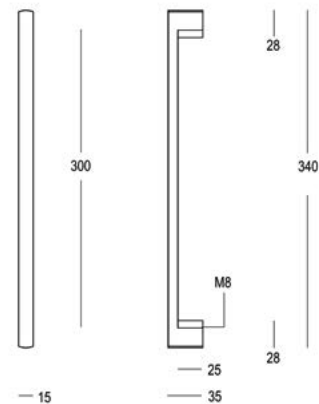



To be specified - À spécifier - Aan te duiden:

Left  
Gauche  
Links

Right  
Droite  
Rechts

199-HK

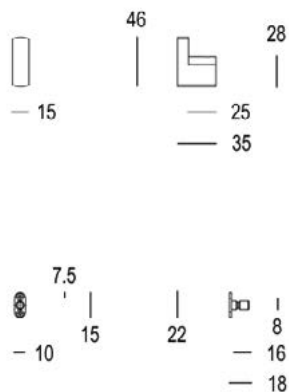

Art. 199-RW (L)

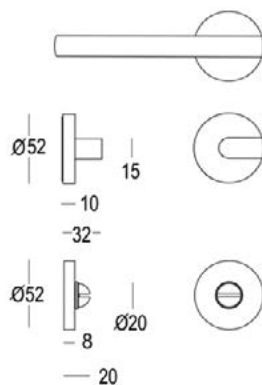

Art. 199-RW (R)

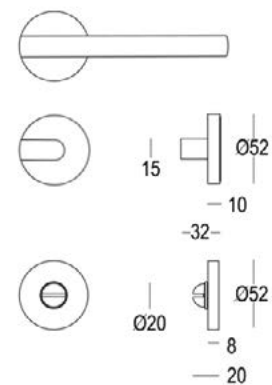



Athena





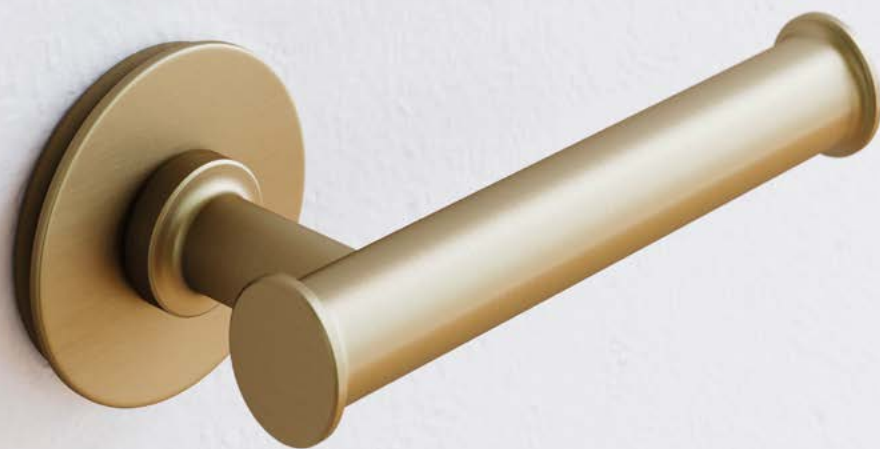

# Athena

Design by Frederik Delbart

Inspired by ancient architecture, the Athena Collection brings the greatness of classic monuments in a subtle form.

*Inspirée de l'architecture ancienne, la collection Athena apporte la grandeur des monuments classiques sous une forme subtile.*

Material: Brass/Laiton DIN 17166

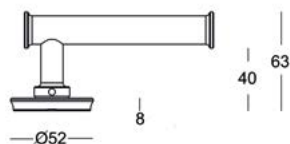
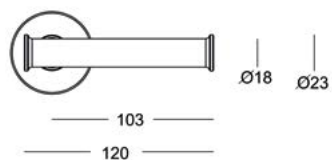

Art. 198-RO



Black textured  
Noir mat structuré  
Mat zwart textuur  
(60)



White textured  
Blanc mat structuré  
Mat wit textuur  
(65)

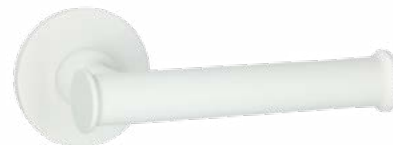

Satin Brass  
Laiton Satiné  
Messing Satijn  
(22)



Matt Bronze  
Bronze Mat  
Mat Brons  
(41)



Inox Look  
Nickel mat satiné  
(99)



# Athena

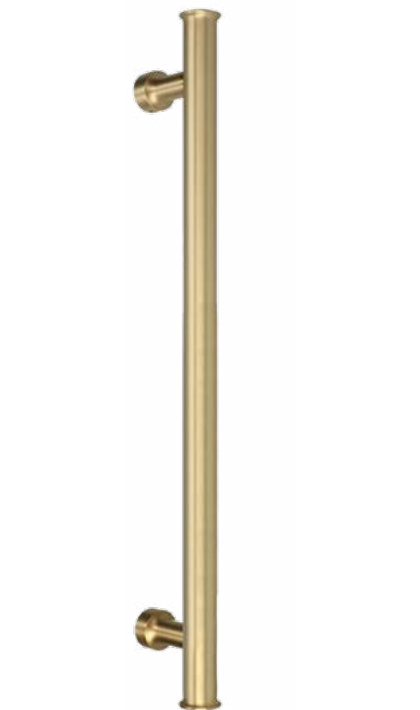

Art. 198-15  
Art. 198-KT



Art. 198-28 (128mm)  
Art. 198-16 (160mm)

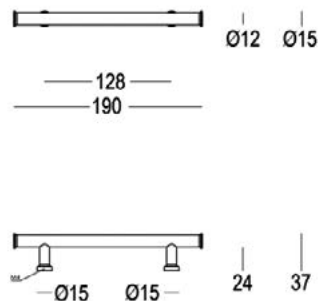

Art. 198-21 (210mm)  
Art. 198-30 (300mm)

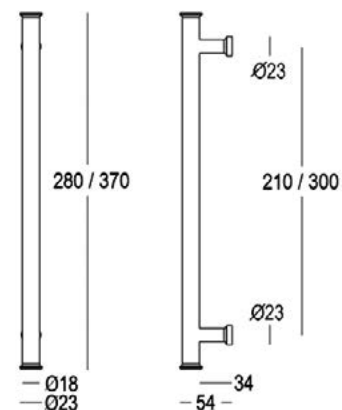



Art. 198-SR

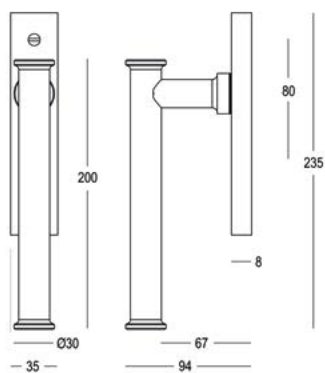

Art. 198-DK (L)  
Art. 198-DK (T)

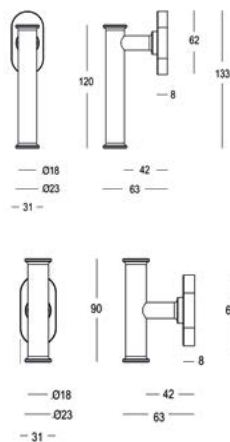

Art. 198-RW

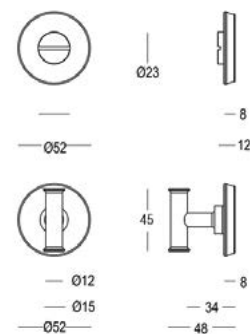





Copenhagen



# Copenhagen

Design by Frederik Delbart



The refined Copenhagen Collection is the result of the evolution of traditional crafted hardware into contemporary design.

*Merveille de raffinement, la collection Copenhagen est le résultat de l'évolution de la quincaillerie artisanale traditionnelle vers le design contemporain.*

Material: Brass/Laiton DIN 17166

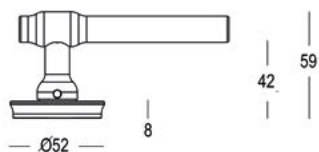
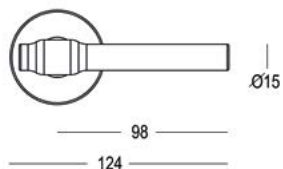

Art. 197-RO



Black textured  
Noir mat structuré  
Mat zwart textuur  
(60)



White textured  
Blanc mat structuré  
Mat wit textuur  
(65)



Satin Brass  
Laiton Satiné  
Messing Satijn  
(22)



Matt Bronze  
Bronze Mat  
Mat Brons  
(41)



Inox Look  
Nickel mat satiné  
(99)



# Copenhagen



Art. 197-14  
Art. 197-KT

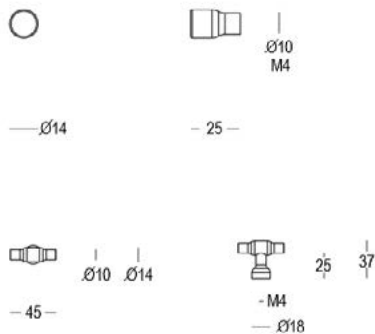

Art. 197-28 (128 mm)  
Art. 197-16 (160 mm)

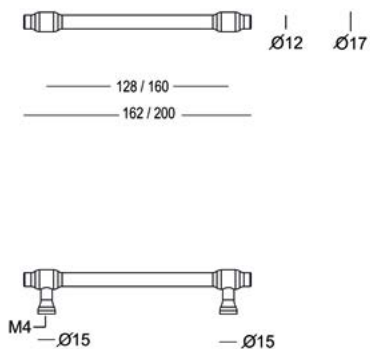

Art. 197-21 (210 mm)  
Art. 197-30 (300 mm)

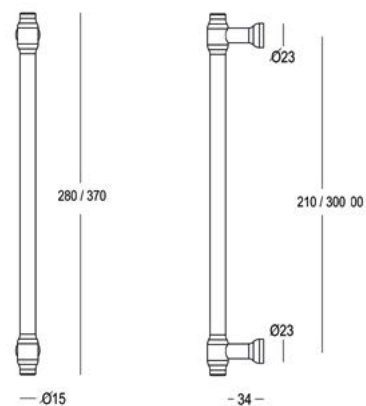



Art. 197-SR

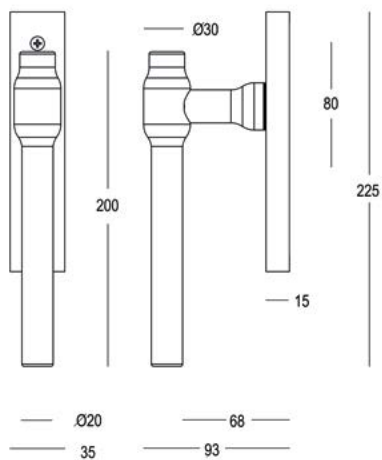

Art. 197-DK (L)  
Art. 197-DK (T)

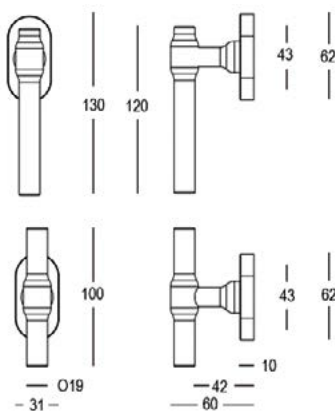

Art. 197-RW

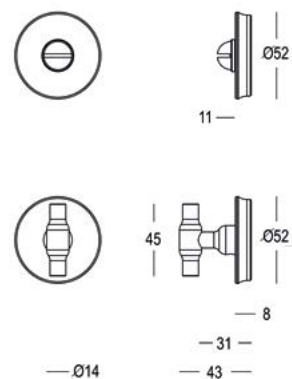



Cassis

Material: Brass/Laiton DIN 17166

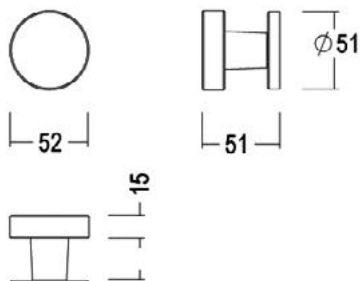

Art. 196-RO



Black textured  
Noir mat structuré  
Mat zwart textuur  
(60)



Satin Brass  
Laiton Satiné  
Messing Satijn  
(22)



Matt Bronze  
Bronze Mat  
Mat Brons  
(41)



Inox Look  
Nickel mat satiné  
(99)





Monaco

Material: Brass/Laiton DIN 17166



— Ø52 —

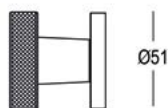

— 8 —

— 36 —

— 51 —

Dark bronze  
Bronze fonçé  
Donker brons  
(42)



Satin Brass  
Laiton Satiné  
Messing Satijn  
(22)



Matt Bronze  
Bronze Mat  
Mat Brons  
(41)



Art. 195-RO



Inox Look  
Nickel mat satiné  
(99)









Como



# Como

Design by Lieven Musschoot & Cas Moor

In the same way that Lake Como creates a Y-silhouette in the mountains, the 'Como collection', is cut out in noble brass.

*Tout comme le lac de Come qui crée une silhouette en forme d'Y dans les montagnes, la collection 'Como', dessinée par Cas Moor et Lieven Musschoot, est découpée dans du laiton massif.*

Material: Brass/Laiton DIN 17166

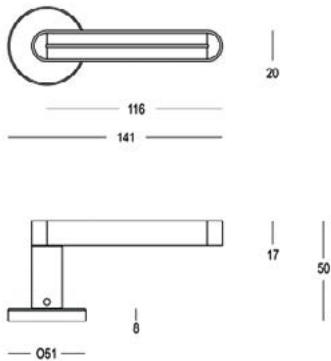

Black textured  
Noir mat structuré  
Mat zwart textuur  
(60)



White textured  
Blanc mat structuré  
Mat wit textuur  
(65)



Satin Brass  
Laiton Satiné  
Messing Satijn  
(22)



Matt Bronze  
Bronze Mat  
Mat Brons  
(41)



Art. 194-RO



# Como

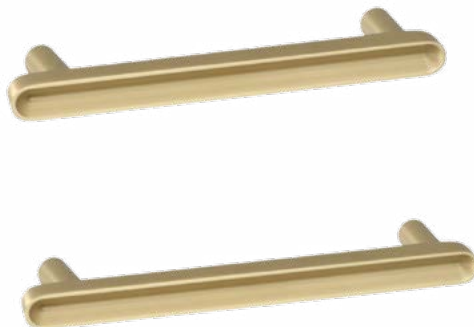

Art. 194-15  
 Art. 194-20  
 Art. 194-KT

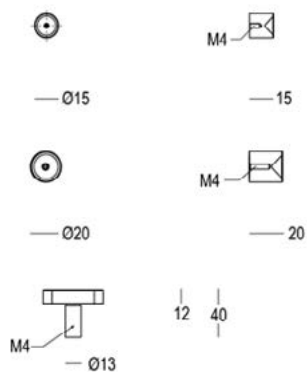

Art. 194-28 (128 mm)  
 Art. 194-16 (160 mm)

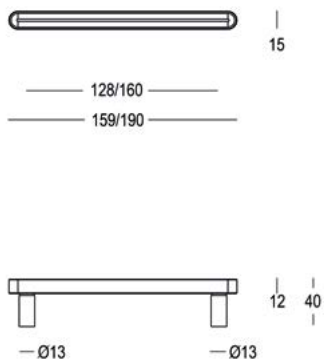

Art. 194-21 (210 mm)  
 Art. 194-30 (300 mm)

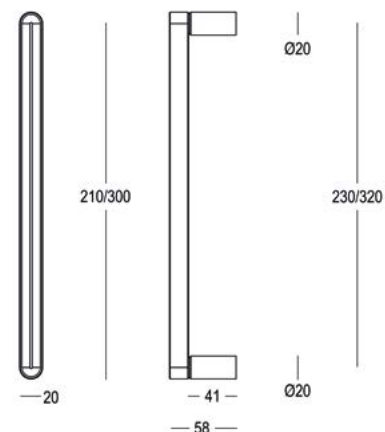



Art. 194-SR

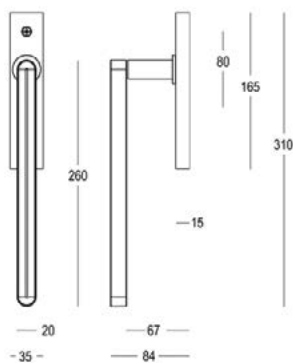

Art. 194-DK (L)

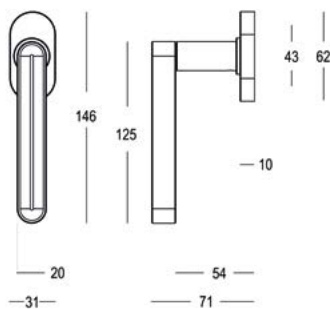

Art. 194-DK (T)

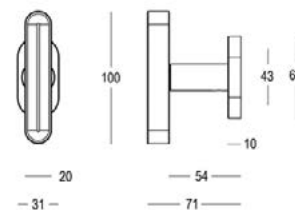





Palma



# Palma

Design by Julien Renault



The Palma Collection gives life to a standard profile reworked into a neat and delicate format. A utilitarian piece of metal with a rhombus profile, the simple grip provides a vast potential.

*La collection Palma donne vie à un profil standard retravaillé dans un format soigné et délicat. Une pièce de métal utilitaire avec un profil en losange, la prise simple offre un vaste potentiel.*

Material: Brass/Laiton DIN 17166

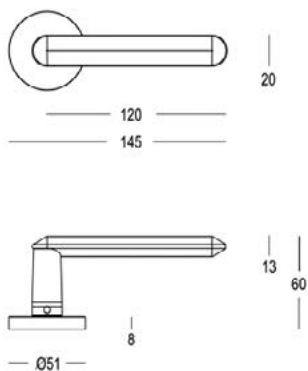

Art. 193-RO



Black textured  
Noir mat structuré  
Mat zwart textuur  
(60)



White textured  
Blanc mat structuré  
Mat wit textuur  
(65)



Satin Brass  
Laiton Satiné  
Messing Satijn  
(22)



Matt Bronze  
Bronze Mat  
Mat Brons  
(41)



Inox Look  
Nickel mat satiné  
(99)



# Palma



Art. 193-KT

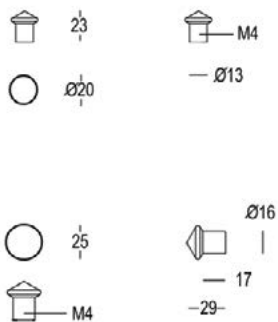

Art. 193-28 (128mm)  
Art. 193-16 (160mm)

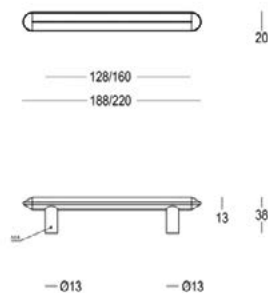

Art. 193-21 (210mm)  
Art. 193-30 (300mm)

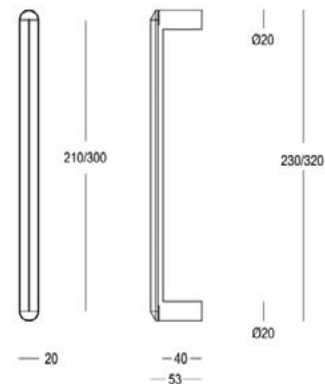



Art. 193-DK (L)

Art. 193-DK (T)

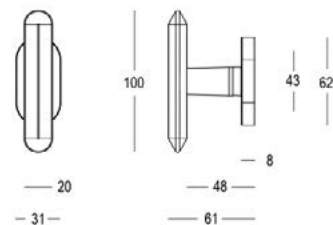
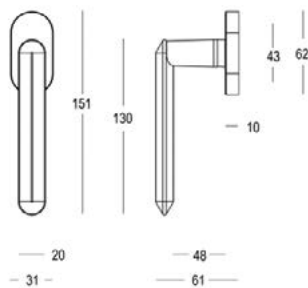



# Oslo

Design by Frederik Delbart

Frederik Delbart found inspiration for his new collection in the minimalistic aesthetic of Nordic Design, which qualities are emphasised in durable, functional, simple and natural forms.

*Frederik Delbart a trouvé inspiration pour sa nouvelle collection dans l'esthétique minimaliste du Design Nordique, dont les qualités sont soulignées dans les formes durables, fonctionnelles, simples et naturelles.*

Material: Brass/Laiton DIN 17166

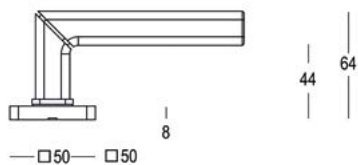
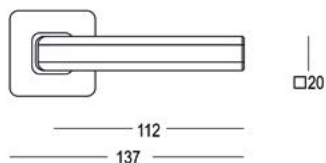

Art. 192-RO



Black textured  
Noir mat structuré  
Mat zwart textuur  
(60)



White textured  
Blanc mat structuré  
Mat wit textuur  
(65)



Satin Brass  
Laiton Satiné  
Messing Satijn  
(22)



Matt Bronze  
Bronze Mat  
Mat Brons  
(41)



Inox Look  
Nickel mat satiné  
(99)



# Oslo



Art. 192-20



—□20



— 27

Art. 192-21 (210 mm)  
Art. 192-30 (300 mm)



— 128/160 —  
— 143/175 —



—□15 —□15

Art. 192-SR

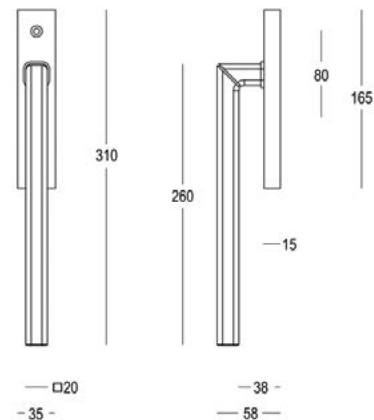



Art. 192-DK

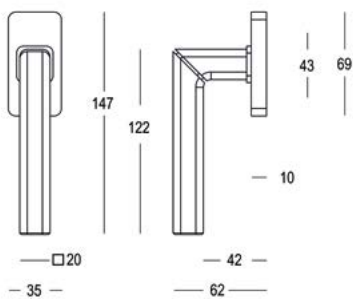

Art. 192-0E  
Art. 192-0C

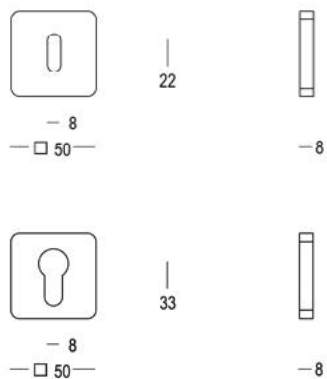

Art. 192-RW

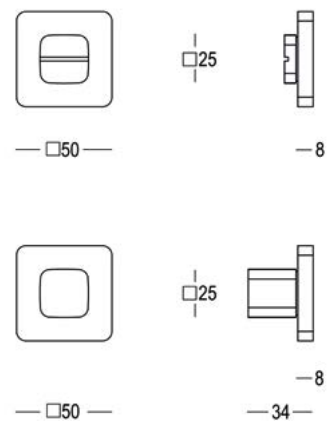



Lausanne



Lausanne, located on the Lac Léman, is well-known for not a its beautiful scenery, but as well as focus of international sport, hosting the International Olympic Committee.

*Lausanne, située au bord du lac Léman, est réputée non seulement pour la beauté de ses paysages, mais aussi parce qu'elle se trouve au coeur des sports internationaux et accueille le Comité International Olympique.*

Material: Brass/Laiton DIN 17166

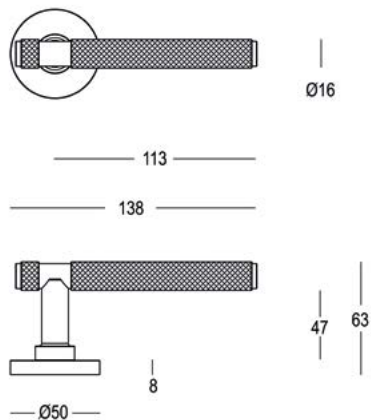

Art. 191-RO

Dark Bronze  
Bronze Foncé  
Donker Brons  
(42)



Satin Brass  
Laiton Satiné  
Messing Satijn  
(22)



Matt Bronze  
Bronze Mat  
Mat Brons  
(41)



Inox Look  
Nickel mat satiné  
(99)







Montreux



Montreux

Montreux, located on the Lac Léman in Switzerland, is the doorway to the Swiss Mountain-region. Numerous mountain-chains, running rivers as well as the Lac Léman carve into the landscape. Quincalux designed a new collection, where new tools are cutting into brass, creating knurled patterns.

*Montreux, située au bord du lac Léman en Suisse, est la porte d'entrée de la région de montagne Suisse. De nombreuses chaînes de montagnes, des rivières courantes ainsi que le lac Léman taillent le paysage. Quincalux a conçu une nouvelle collection, dans laquelle de nouveaux outils coupent le laiton et créent des motifs guillochés.*

Material: Brass/Laiton DIN 17166

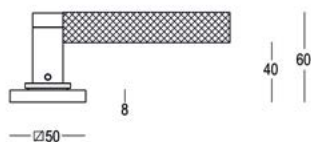
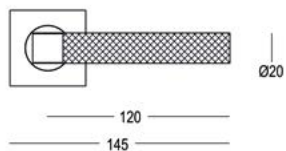

Dark Bronze  
Bronze Foncé  
Donker Brons  
(42)



Satin Brass  
Laiton Satiné  
Messing Satijn  
(22)



Matt Bronze  
Bronze Mat  
Mat Brons  
(41)



Inox Look  
Nickel mat satiné  
(99)



Art. 190-RO



# Montreux



Art. 190-20

Art. 190-28 (128 mm)  
Art. 190-16 (160 mm)

Art. 190-21 (210 mm)  
Art. 190-30 (300 mm)

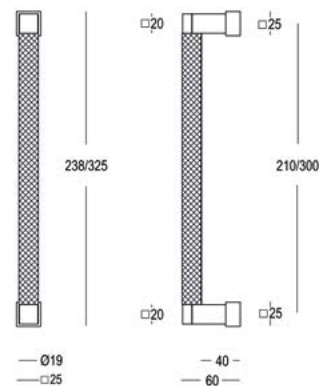
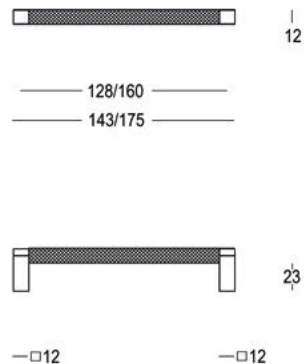
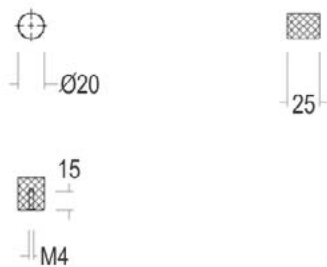



Art. 190-SR

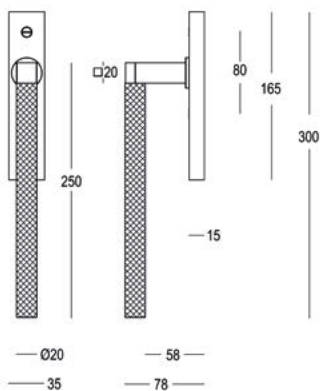

Art. 190-DK

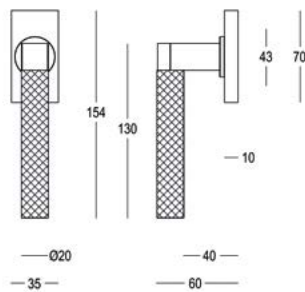

Art. 190-RW

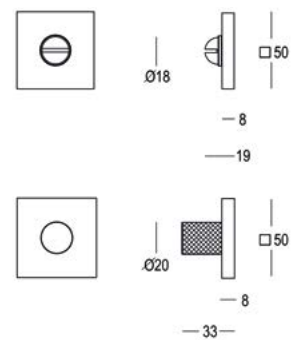







Royal



# Royal

Design by Frederik Delbart

The Royal Collection lets classicism and modernity collide, drawing the eye through the gentle grooves, as the monolithic design takes its inspiration from the traditional columns of Ancient Rome.

*Collection Royal fusionne le classicisme et de la modernité, en attirant le regard à travers des douces rainures, tandis que le design monolithique s'inspire des colonnes traditionnelles de la Rome antique.*

Material: Brass/Laiton DIN 17166

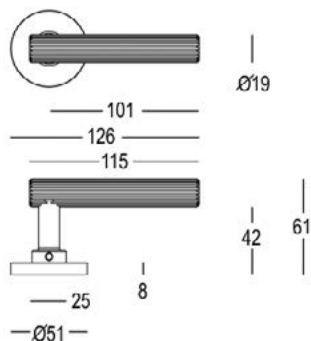

Art. 167-RO



Black textured  
Noir mat structuré  
Mat zwart textuur  
(60)



White textured  
Blanc mat structuré  
Mat wit textuur  
(65)



Satin Brass  
Laiton Satiné  
Messing Satijn  
(22)



Matt Bronze  
Bronze Mat  
Mat Brons  
(41)



Inox Look  
Nickel mat satiné  
(99)



# Royal

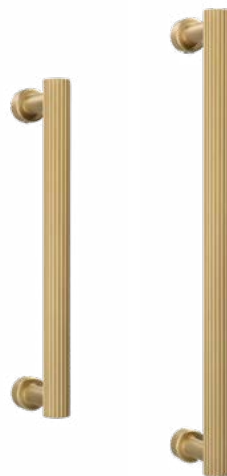

Art. 167-12 (d/12mm)  
Art. 167-20 (d/20mm)

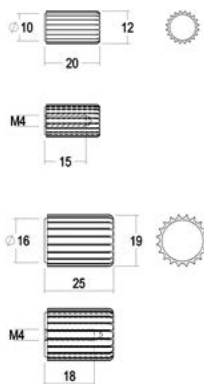

Art. 167-96 (96 mm)  
Art. 167-128 (128 mm)

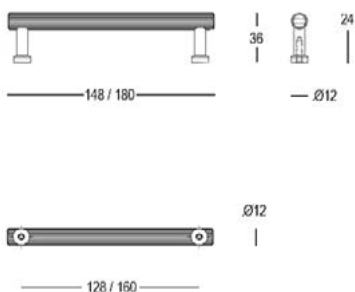

Art. 167-21 (210 mm)  
Art. 167-30 (300 mm)

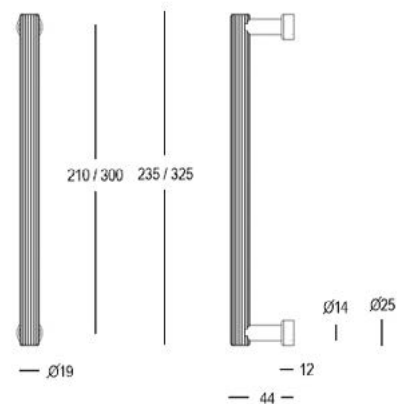



Art. 167-SR

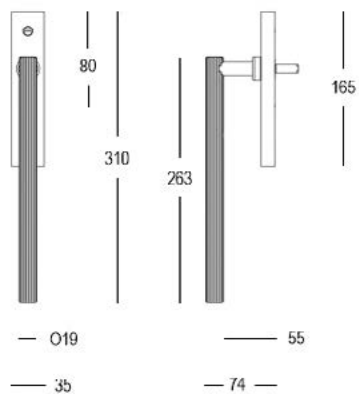

Art. 167-DK (L)  
Art. 167-DK (T)

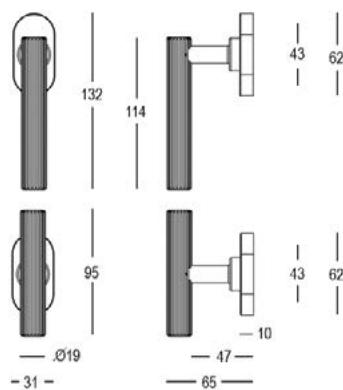

Art. 167-RW

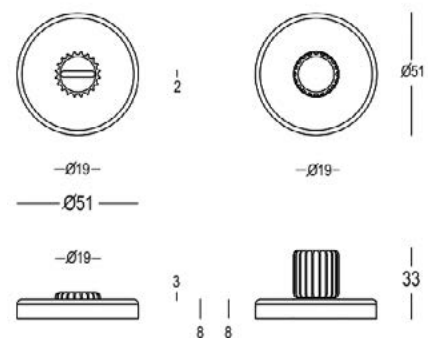



# Quito

Design by Frederik Delbart

Form follows function is the mantra of the Quito door handle. While removing all that is unnecessary, this doorhandle is about the essence of purity.

*'La forme suit la fonction': mantra de la poignée de porte Quito. Tout en supprimant tout ce qui est inutile, cette poignée de porte est l'essence même de la pureté.*

Material: Brass/Laiton DIN 17166

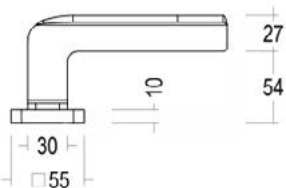
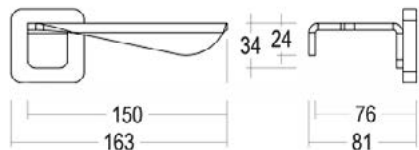

Art. 165-RO



Black textured  
Noir mat structuré  
Mat zwart textuur  
(60)



White textured  
Blanc mat structuré  
Mat wit textuur  
(65)



Satin Brass  
Laiton Satiné  
Messing Satijn  
(22)



Matt Bronze  
Bronze Mat  
Mat Brons  
(41)



Inox Look  
Nickel mat satiné  
(99)





# Caracas

Design by Frederik Delbart



The Caracas door handle is made from a single sheet of brass that is laser cut and bent by hand. Craftmanship and technology meet in this innovative design.

*La poignée de porte Caracas est réalisée d'une seule feuille de laiton, découpée par laser et ensuite pliée à la main. L'artisanat et la technologie se rencontrent dans cette conception innovante.*

Material: Brass/Laiton DIN 17166

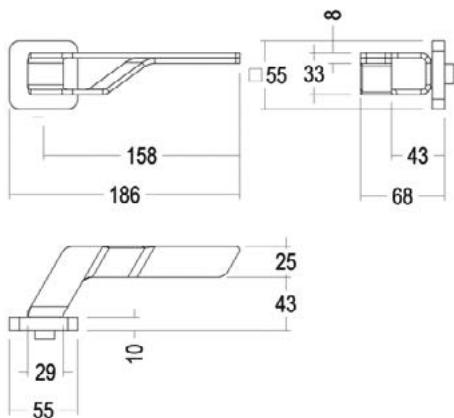

Art. 163-RO



Black textured  
Noir mat structuré  
Mat zwart textuur  
(60)



White textured  
Blanc mat structuré  
Mat wit textuur  
(65)



Satin Brass  
Laiton Satiné  
Messing Satijn  
(22)



Matt Bronze  
Bronze Mat  
Mat Brons  
(41)



Inox Look  
Nickel mat satiné  
(99)



# Q-wing

Design by Quincalux Design Studio

The Q-wing doorhandle is the result of an experiment in new technology, whereas the shape takes its inspiration from a seagull's wings.

*La poignée de porte Q-wing est le résultat d'une expérimentation de nouvelles technologies, tandis que la forme s'inspire des ailes d'une mouette .*

Material: Brass/Laiton DIN 17166

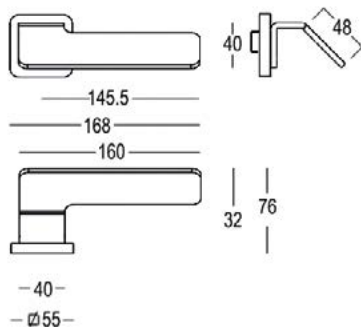

Art. 161-R0



Black textured  
Noir mat structuré  
Mat zwart textuur  
(60)



White textured  
Blanc mat structuré  
Mat wit textuur  
(65)



Satin Brass  
Laiton Satiné  
Messing Satijn  
(22)



Matt Bronze  
Bronze Mat  
Mat Brons  
(41)



Inox Look  
Nickel mat satiné  
(99)



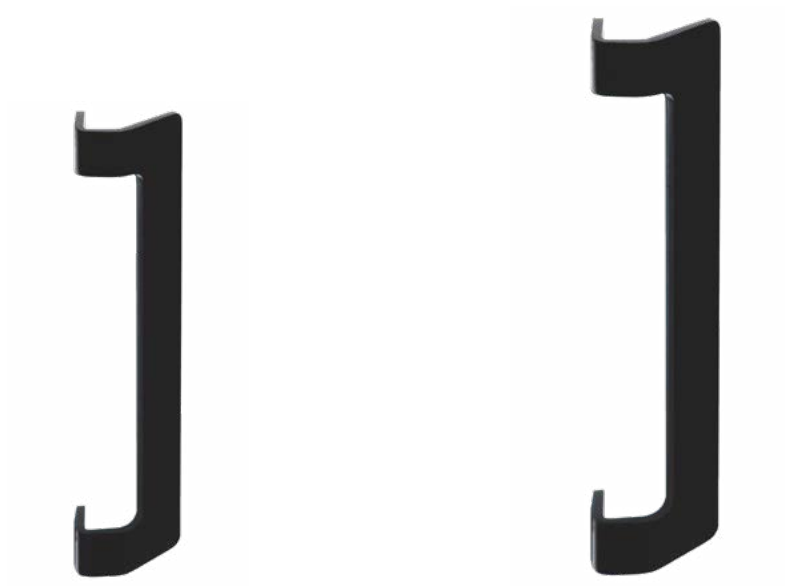

Art. 162-30 (300mm)

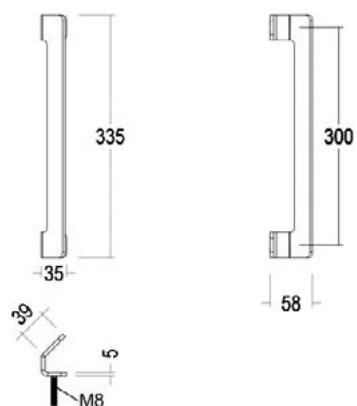

Art. 161-65 (650mm)

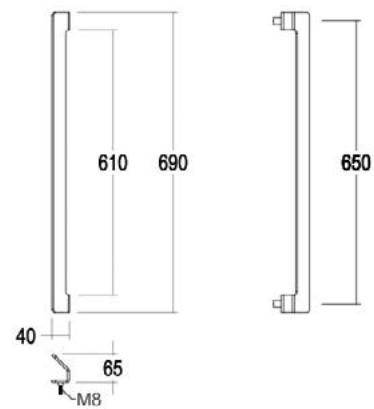



Stockholm

Elegant and classy collection, matching contemporary as well as classic interiors.

*Une collection élégante et raffinée, adaptée aux intérieurs contemporains ou classiques.*

Material: Brass/Laiton DIN 17166

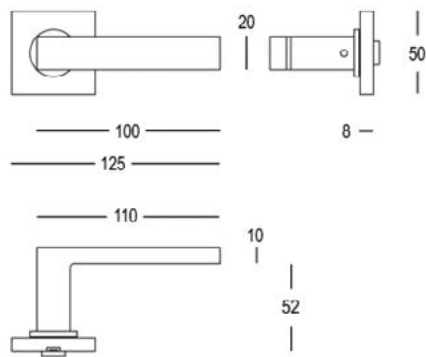

Art. 159-RO



Black textured  
Noir mat structuré  
Mat zwart textuur  
(60)



White textured  
Blanc mat structuré  
Mat wit textuur  
(65)



Satin Brass  
Laiton Satiné  
Messing Satijn  
(22)



Matt Bronze  
Bronze Mat  
Mat Brons  
(41)



Inox Look  
Nickel mat satiné  
(99)



# Stockholm



Art. 159-20

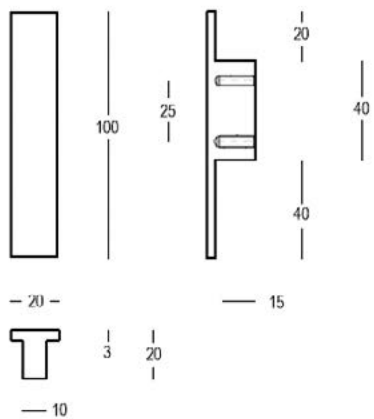

Art. 159-25

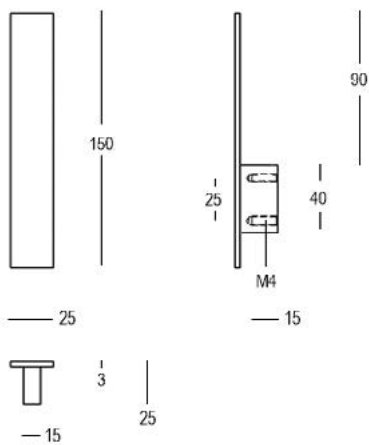



Art. 159-21

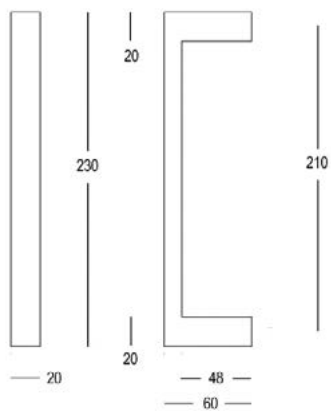

Art. 159-SR

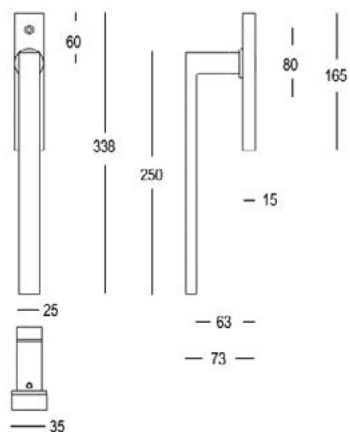

Art. 159-DK (L)

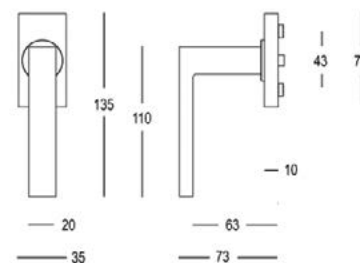



Luxembourg



Beautiful collection marked by its straight and linear lines.

*Une splendide collection marquée par ses lignes droites et linéaires.*

Material: Brass/Laiton DIN 17166

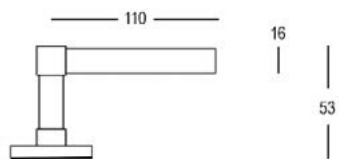
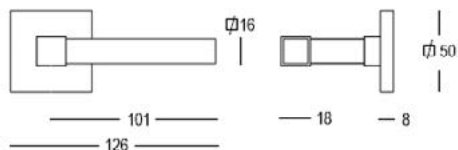

Art. 158-RO



Black textured  
Noir mat structuré  
Mat zwart textuur  
(60) (ALU)



White textured  
Blanc mat structuré  
Mat wit textuur  
(65) (ALU)



Satin Brass  
Laiton Satiné  
Messing Satijn  
(22)



Matt Bronze  
Bronze Mat  
Mat Brons  
(41)



Inox Look  
Nickel mat satiné  
(99)



# Luxembourg



Art. 158-50

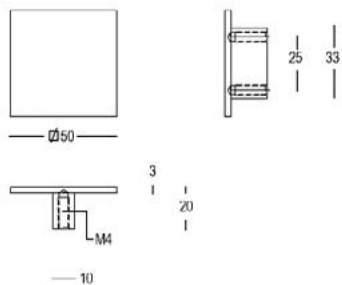

Art. 158-35

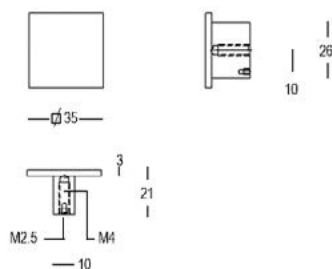

Art. 158-25

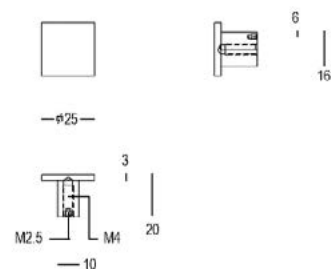



Art. 158-30

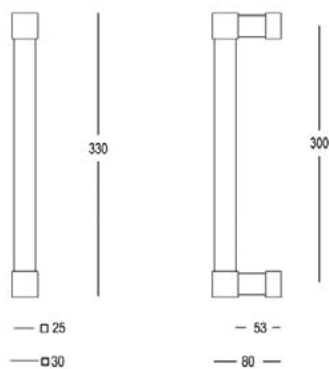

Art. 158-SR

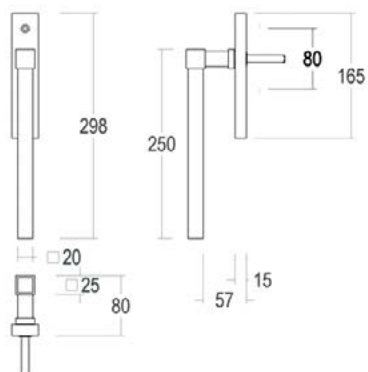

Art. 158-DK (L)

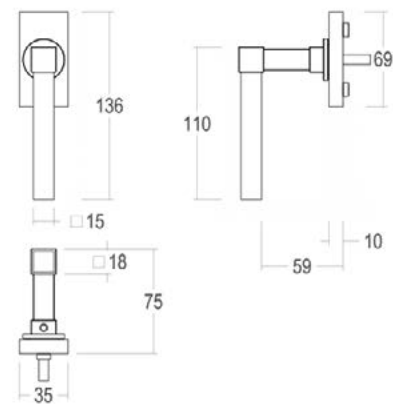



Berlin

Berlin is a city of architectural contrasts, where historical buildings stand alongside modern architecture as the past and present intermingle. The Berlin collection by Quincalux is marked by square forms combined with round, circular handle part.

*La ville de Berlin se distingue par ses contrastes architecturaux. Les bâtiments historiques y côtoient une architecture moderne où se confondent passé et présent. La collection Berlin de Quincalux affiche des formes carrées alliées à un élément rond et circulaire.*

Material: Brass/Laiton DIN 17166

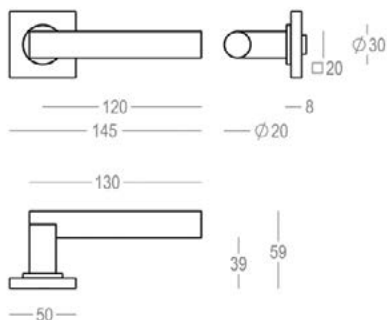

Art. 157-RO



Black textured  
Noir mat structuré  
Mat zwart textuur  
(60) (ALU)



White textured  
Blanc mat structuré  
Mat wit textuur  
(65) (ALU)

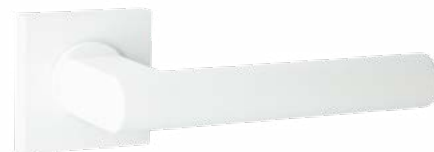

Satin Brass  
Laiton Satiné  
Messing Satijn  
(22)



Matt Bronze  
Bronze Mat  
Mat Brons  
(41)



Inox Look  
Nickel mat satiné  
(99)





*Photographe: Didier Delmas  
Hôtel Les Roches Blanches (5\*), Cassis (F)  
Agence Kappel Architectes*





Luxor



The name of this handle clearly refers to a typical Egyptian structure; the seizable part of the handle having a pyramidal shape.

*Le nom de cette poignée fait clairement référence à une structure typiquement égyptienne, avec sa prise de main de forme pyramidale.*

Material: Brass/Laiton DIN 17166

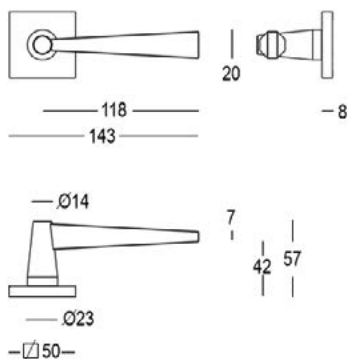

Art. 156-RO



Black textured  
Noir mat structuré  
Mat zwart textuur  
(60)



White textured  
Blanc mat structuré  
Mat wit textuur  
(65)



Satin Brass  
Laiton Satiné  
Messing Satijn  
(22)



Matt Bronze  
Bronze Mat  
Mat Brons  
(41)



Inox Look  
Nickel mat satiné  
(99)





Lisbon

Starting with a round rose, followed by a smoothly bended rounded off handle.  
Resulting in an elegant and ergonomic handle.

*Commençant par une rose ronde, suivie d'une poignée arrondie et délicatement courbée, elle donne vie à une élégante poignée ergonomique.*

Material: Brass/Laiton DIN 17166

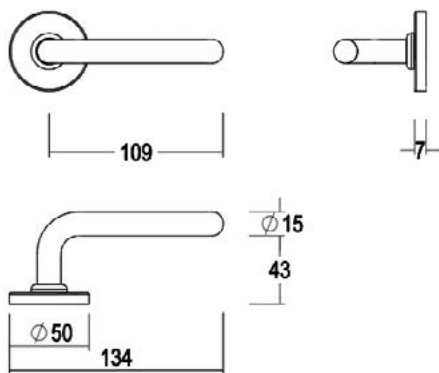

Art. 153-RO



Black textured  
Noir mat structuré  
Mat zwart textuur  
(60)



White textured  
Blanc mat structuré  
Mat wit textuur  
(65)



Satin Brass  
Laiton Satiné  
Messing Satijn  
(22)



Matt Bronze  
Bronze Mat  
Mat Brons  
(41)



Inox Look  
Nickel mat satiné  
(99)





Madrid

The Madrid handle is marked by a timeless and practical beauty of a kind...

*La poignée Madrid respire la beauté intemporelle et pratique...*

---

Material: Brass/Laiton DIN 17166

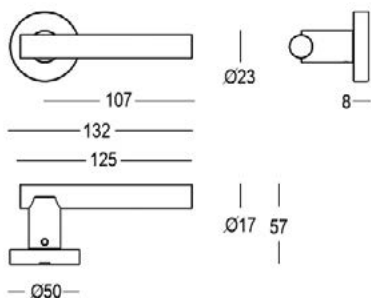

---

Art. 152-RO



Black textured  
Noir mat structuré  
Mat zwart textuur  
(60)



Satin Brass  
Laiton Satiné  
Messing Satijn  
(22)



Matt Bronze  
Bronze Mat  
Mat Brons  
(41)



Inox Look  
Nickel mat satiné  
(99)





*Hotel Le Sanglier des Ardennes, Durbuy (B)*  
*Photography: Oriana Gomez-Zerpa*





Brussels



The '124' collection was created by Quincalux in 1965, 130 years after the inauguration of the first European railway between Brussels and Mechelen.

The inspiration came from the hardware designed for the interiors of the famous Orient Express, produced by the Belgian company CIWL.

*La collection « 124 » a été créée par Quincalux en 1965, 130 ans après l'inauguration du premier chemin de fer continentale, entre Bruxelles et Malines. Toutefois, elle puise son inspiration de la quincaillerie conçue pour le célèbre Orient Express, produite par la société belge CIWL.*

Material: Brass/Laiton DIN 17166

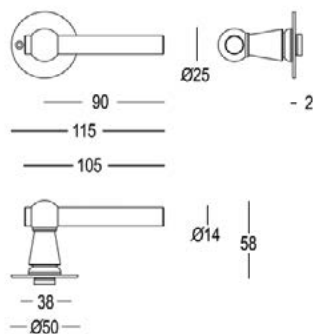

Art. 124-LO



Black textured  
Noir mat structuré  
Mat zwart textuur  
(60)



White textured  
Blanc mat structuré  
Mat wit textuur  
(65)



Satin Brass  
Laiton Satiné  
Messing Satijn  
(22)



Matt Bronze  
Bronze Mat  
Mat Brons  
(41)



Inox Look  
Nickel mat satiné  
(99)



# Brussels



Art. 124-KT

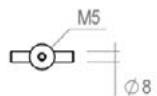
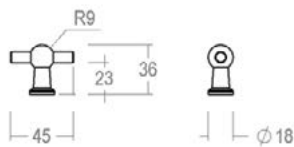

Art. 124-96 (96mm)  
Art. 124-28 (128mm)

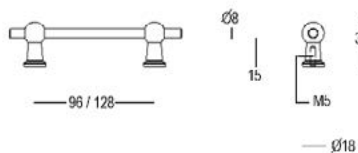
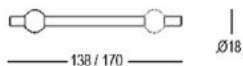

Art. 124-DS

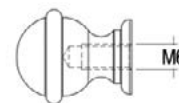
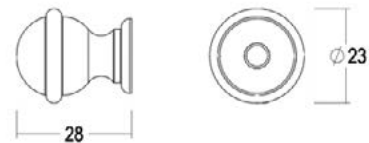



Art. 124-SR

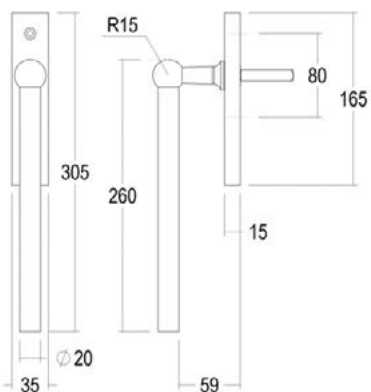

Art. 124-DK (L)  
Art. 124-DK (T)

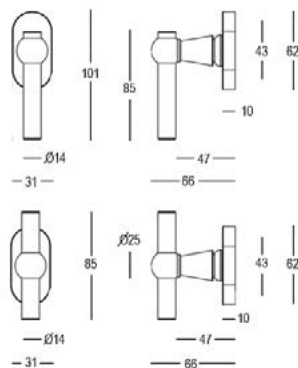

Art. 124-RW

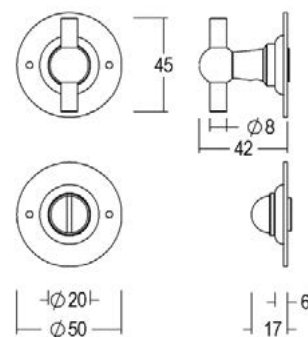
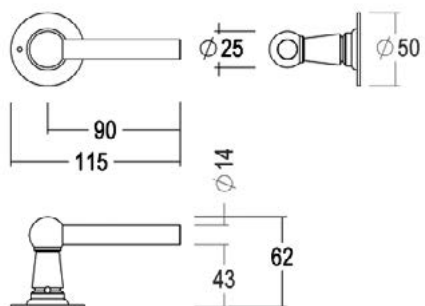



Photo: Steelit

Material: Brass/Laiton DIN 17166



Art. 127-RO

Material: Brass/Laiton DIN 17166

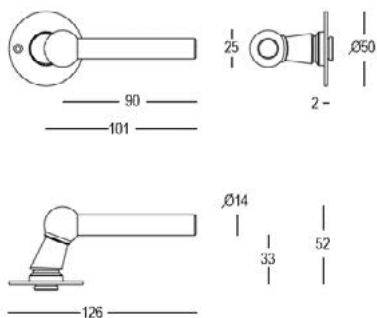

Art. 127-DO

# Q-line



Material: Aluminium EN.AW.6060

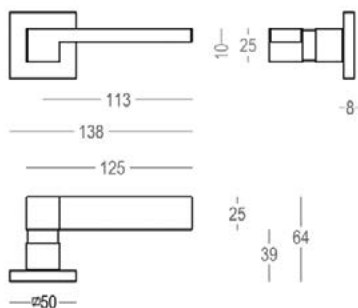

Black textured  
Noir mat structuré  
Mat zwart textuur  
(60)



White textured  
Blanc mat structuré  
Mat wit textuur  
(65)



Smoke  
(50)



Art. 700-RO

# Q-line



Material: Aluminium EN.AW.6060

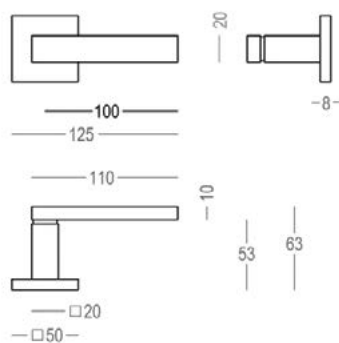

Black textured  
Noir mat structuré  
Mat zwart textuur  
(60)



White textured  
Blanc mat structuré  
Mat wit textuur  
(65)



Smoke  
(50)



Art. 701-RO

# Q-line



---

Material: Aluminium EN.AW.6060

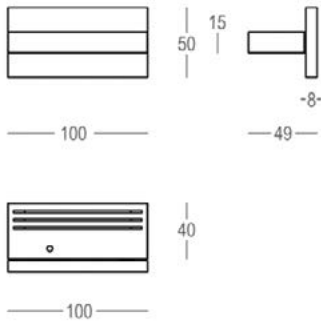

Black textured  
Noir mat structuré  
Mat zwart textuur  
(60)



White textured  
Blanc mat structuré  
Mat wit textuur  
(65)



Smoke  
(50)



---

Art. 703-RO



# Q-line



Material: Aluminium EN.AW.6060

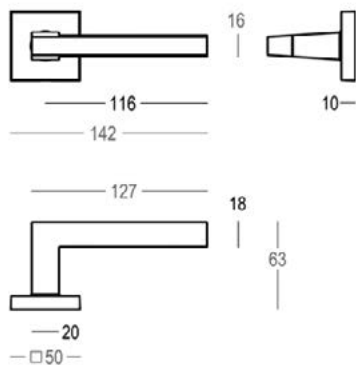

Black textured  
Noir mat structuré  
Mat zwart textuur  
(60)



White textured  
Blanc mat structuré  
Mat wit textuur  
(65)

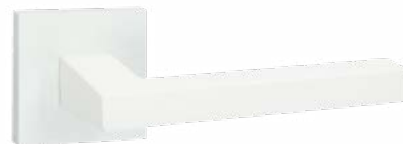

Art. 704-RO

Art. 138-25

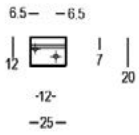
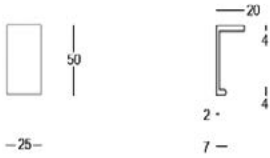

Art. 138-50

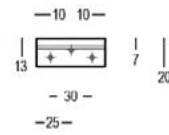
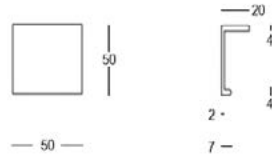

Art. 138-75

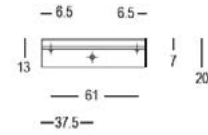
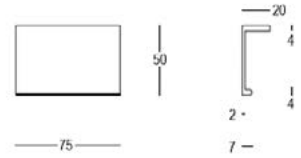

Art. 139-50

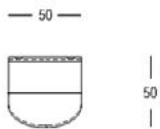
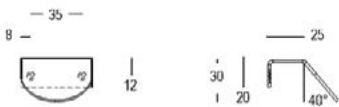

Art. 139-75

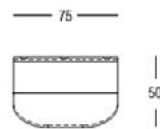
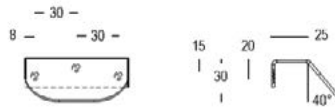

Art. 139-15

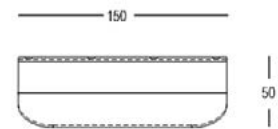
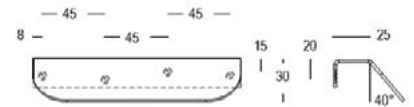

Art. 159-20

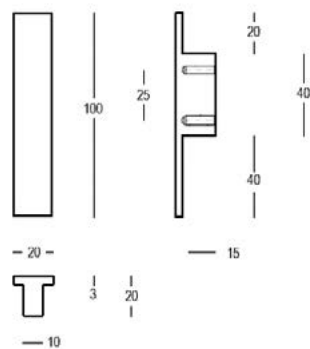

Art. 159-25

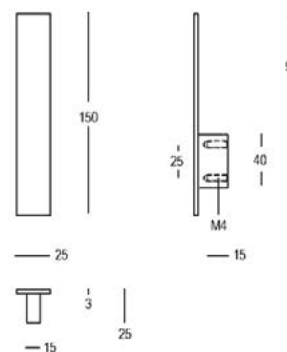

Art. 158-25

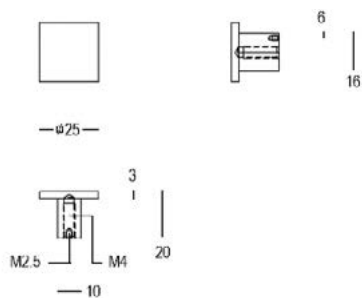

Art. 158-35

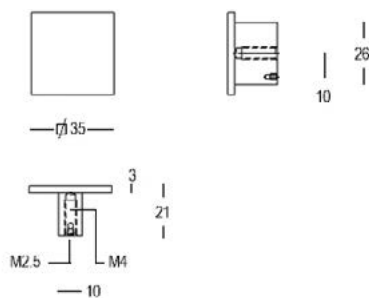

Art. 158-50

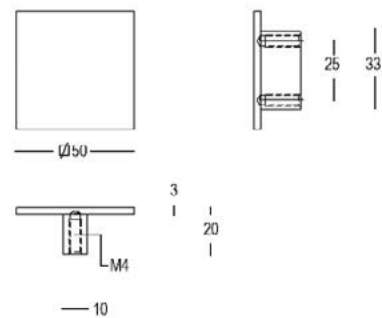

Monaco Art.195-30 (30mm)



— 14

— 19

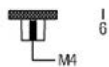

Monaco Art.195-40 (40mm)

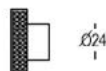

— 14

-22-

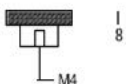

Cassis Art.196-30 (30mm)



— 14

— 19

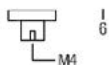

Cassis Art.196-40 (40mm)

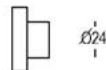

— 14

-22-

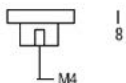



Art. 690-30

Art. 691-DS

Art.190-DS

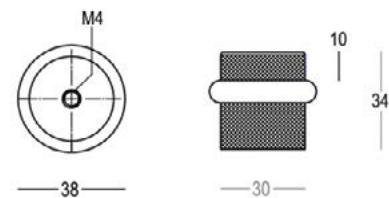
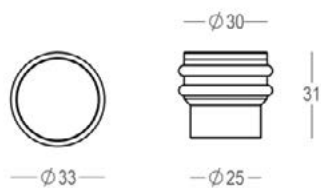
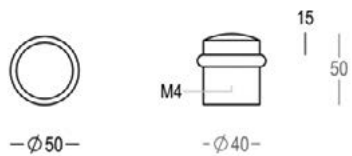

Q 1942



Black textured matt Powder Coat  
Laque poudre noir mat texture  
Zwart textuur poederlak  
RAL 9005 (60)



dark bronzed  
bronze foncé  
donker brons  
(42)



matt bronze  
bronze mat  
mat brons  
(41)



bright bronze  
bronze brillant  
brons b4  
(04)



Rust textured matt Powder Coat  
Rouille Lacque poudre texture  
Roest textuur poederlak  
(63)



antique brass  
laiton antique  
atm  
(26)



satin brass  
laiton satiné  
messing satijn  
(22)



bright brass  
laiton brillant  
messing glanzend  
(01)



white textured matt powder coat  
laque poudre blanc mat texture  
wit mat textuur poederlak  
RAL 9016 (65)



antique gun finish  
antique étin  
TIN  
(96)



satin nickel  
nickel satiné  
satijn nikkel  
(99)



bright nickel  
nickel brillant  
blinkend nikkel  
(09)

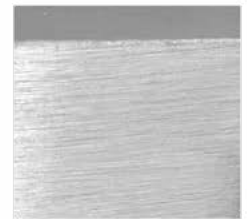

aluminium anodized natural  
aluminium anodisé naturel  
Smoke  
(50)



indoor & outdoor use  
*utilisation intérieure et extérieure*



Quincalux NV  
Kouterstraat 7, 8560 Wevelgem, Belgium

T +32 (0)56 43 53 63  
F +32 (0)56 43 53 60

[sales@quincalux.com](mailto:sales@quincalux.com)  
[www.quincalux.com](http://www.quincalux.com)

DOWNLOAD CATALOGUE

